

Bulk Capacity - 16 oz. (473 cm³)
Cartridge Capacity - 14-1/2 oz. (429 cm³)

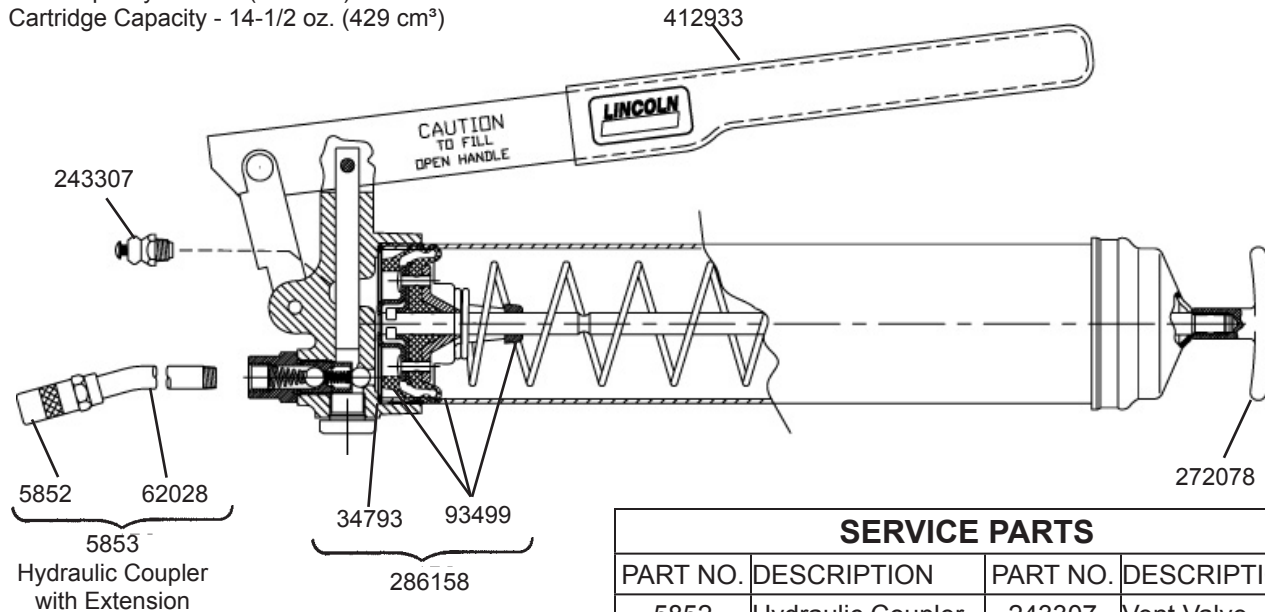

SERVICE PARTS

PART NO.	DESCRIPTION	PART NO.	DESCRIPTION
5852	Hydraulic Coupler	243307	Vent Valve
34793	Container Packing	272078	Follower Handle
62028	Nozzle Extension	286158	Follower Kit
93499	Follower Assembly	412933	Hand Grip

⚠ WARNING

Extreme pressure may cause nozzle extension or whip hose to burst. Use only LINCOLN APPROVED hoses and follow whip hose instructions and warnings.

⚠ WARNING

Grease gun can develop high pressure up to 7,000 P.S.I. (483 BAR). Use safety glasses and gloves for protection during operation. Keep hands clear of the extension during operation of the grease gun.

OPERATING INSTRUCTIONS

Fill the lubricant container Refer to reverse page for instructions.

Wipe fittings clean before lubricating. Push coupler onto fitting at slight angle and then center coupler on the fitting Operate lever gun handle to lubricate taking care not to damage seals by excessive pressure or lubricant volume After lubricating turn coupler at a slight angle to release grip of the coupler jaws

TO INSTALL A LUBRICANT CARTRIDGE

- 1) Loosen the pump head 2-3 rotations.
- 2) Pull back on the follower handle until the follower rod is fully extended, approximately 8 inches; pull it sideways to latch the rod groove into the keyhole slot in the container cap.
- 3) Remove the pump head from container tube.
- 4) If there is an empty lubricant cartridge, carefully release the follower handle to eject it from the container tube.
- 5) If an empty lubricant cartridge was expelled, pull back on the follower handle again and re-lock the rod groove into the keyhole slot in the container cap.
- 6) Remove the plastic cap from the end of the new lubricant cartridge and insert the open end of the cartridge into the container tube.

- 7) Remove the metal pull-tab from the lubricant cartridge.
- 8) Thread the container tube assembly onto the head assembly at least two full turns.
- 9) Pull the follower handle to release the follower rod from the container cap.
- 10) Rotate the follower handle to engage the rod onto the follower assembly. Slightly push the follower handle forward to expel air between the thread interface of head and tube.
- 11) Finish threading the tube assembly into the pump head until tight.
- 12) Disengage the follower rod from the follower by rotating the follower handle and push the follower rod into the container.

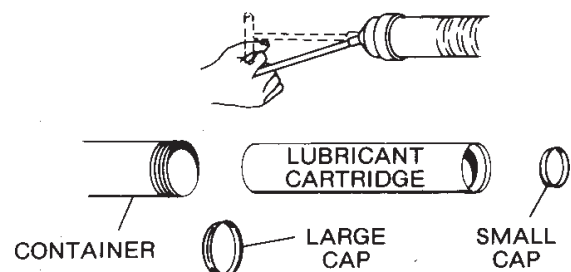

TO FILL LEVER GUN FROM BULK LUBRICANT CONTAINER

- 1) Remove head and plunger assembly from container tube.
- 2) Pack lubricant into cavity of the head and plunger assembly.
- 3) Insert the open end of the container tube into lubricant. Slowly pull the follower handle back while pushing the container tube deeper into the lubricant to prevent air pockets from being pulled into the container tube.
- 4) When the follower rod is fully extended pull it sideways to latch the rod groove into the keyhole slot in the container cap.
- 5) Loosely assemble the head and plunger assembly to the filled container tube. Release the follower rod from the container cap and disengage the follower rod from the follower by rotating the follower handle. Push the follower rod into the container. Slowly unscrew the container tube from the head and plunger assembly until lubricant oozes from the interface. Tighter container tube into the head and plunger assembly.

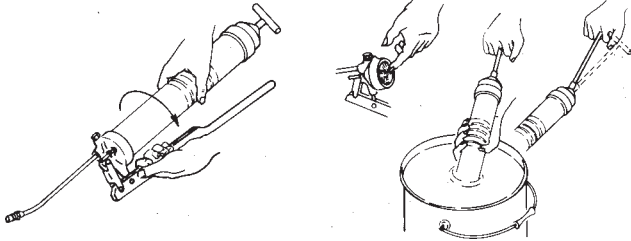

AIR PURGING INSTRUCTIONS

- 1) Engage the follower rod and piston by rotating the follower "T" handle.
- 2) Press the follower "T" handle against your chest with the gun pointing upward. At the same time, press the bleeder valve until all air is expelled and grease oozes from the valve.
- 3) Pump gun handle until grease flow is uniform and consistent.
- 4) Repeat procedure if gun stops pumping at any time.

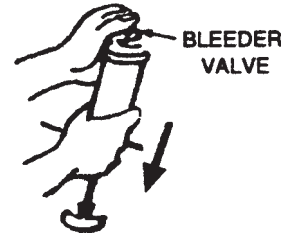

Americas:
One Lincoln Way
St. Louis, MO 63120-1578
USA
Phone +1.314.679.4200
Fax +1.800.424.5359

Europe/Africa:
Heinrich-Hertz-Str 2-8
D-69183 Walldorf
Germany
Phone +49.6227.33.0
Fax +49.6227.33.259

Asia/Pacific:
25 Int'l Business Park
#01-65 German Centre
Singapore 609916
Phone +65.562.7960
Fax +65.562.9967

© Copyright 2009
Printed in USA

Web site:
www.lincolnindustrial.com